

MCP737PRO

(THIS MANUAL IS SUITABLE FOR THE “MCP737PRO” VERSION)



This manual is intended for Flight Simulator use only and may not be used in any real world aviation application. The authors are not responsible for any errors or omissions.

FOREWORD

Thank you for purchasing the CPflight MCP737PRO hardware. To optimize the performance of this unit, please read through this manual carefully. This manual gives you the information to connect and use MCP737PRO panel with Microsoft Flight simulator and Project Magenta. Even if the MCP737PRO support the mainly used FS add-on software, it is not possible to assure the full compatibility with all third part add-on. To know more about the compatibility with a specific add-on aircraft please refer to the latest informations on the CPflight website “compatibility” page.

Note: This manual contains the latest information at the time of drafting. Due to the continuous evolving of the product some features could be been modified. Eventual later informations can be found at CPflight website www.cpflight.com

The CPflight modules are produced to meet requirements from the hobby market. The use of our products in professional or commercial environments is not permitted without approval of the CPflight management; please contact us at info@cpflight.com if you need to exploit our products in professional or commercial environments.

MCP737PRO is a full scale replica of the Boeing 737NG Mode Control Panel, look and functionality are reproduced with high details. MCP737PRO is equipped with high quality level components: high reliability encoders, autothrottle ARM switch with electromagnetic disengage and bank selector knob gives a high fidelity performances and a never seen realism.

Note: It is important to know that the hardware have not its own intelligence on board, it establish an interface with the connected software; logics, operating modes and aircraft behavior are managed by the software itself.

HARDWARE INSTALLATION

The MCP737PRO is designed for panel assembly. The MCP737PRO is intended as a part to be inserted in a cockpit reproduction, CPflight does not produce chassis or other mechanical parts for the cockpit structure, so the panel is intended to be inserted in your own cockpit glare shield. To fix the MCP cut out your panel according with the dimensions quoted at the last page of this manual. Fixing screws are not provided as depending by the thickness and/or material of your glare shield panel, different screws can be required.

In your glare shield structure maintain the accessibility to the back of the MCP to allows working to the connections and eventual future firmware upgrades (see following).

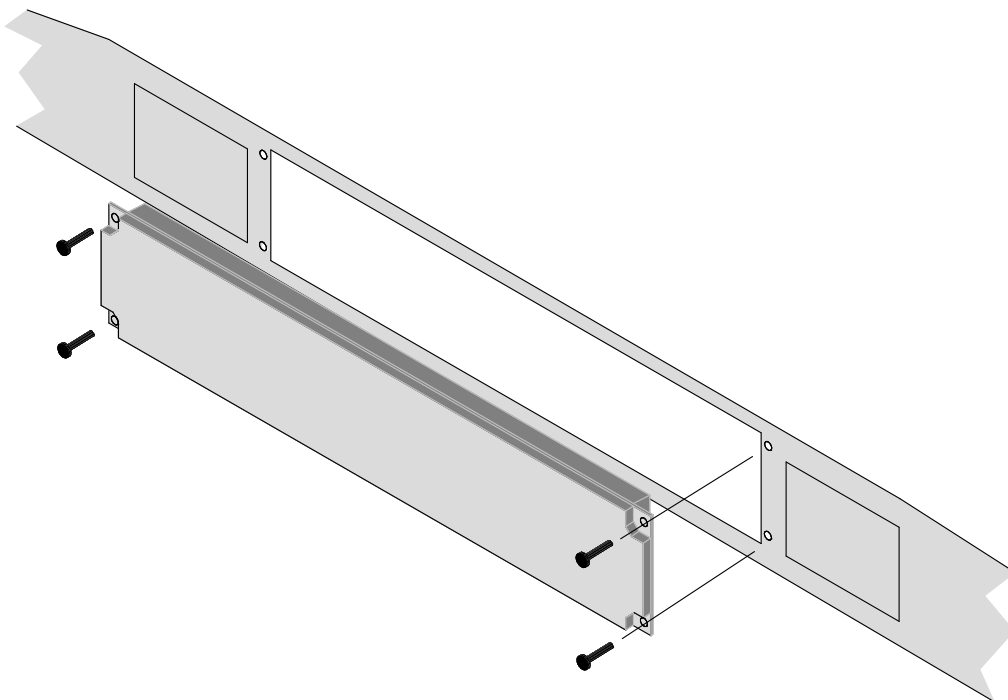

CONNECTIONS

The MCP is provided with a universal supply adapter that accepts a voltage of 100 to 240Vac (50/60Hz). Supply adapter and USB cable are provided with the MCP, you don't need further hardware to operate. Sockets for connections are on the back of panel (Figure 1). Beyond to the supply and USB connectors the MCP737PRO have some further sockets, they are provided to allow system expandability. A DIN 5 pole socket "C" is used to link auxiliary CPflight modules (MIP737 board, Radios etc). Close to USB socket, there is a small 6-pole connector ready for external backlight control, external A/T disengage pushbutton and external TO/GA pushbutton. The 6-pole connector is intended as 3 x 2 pole each pair of pole support one of the functions as indicated in the below connector list items E, F and G.

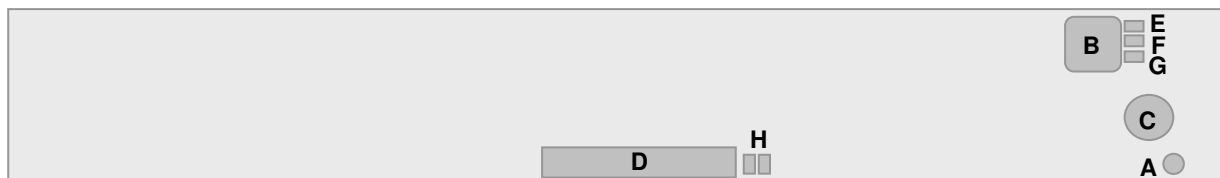

Figure 1: Connectors (back view)

- A - Power supply socket
- B - USB
- C - 5 poles DIN socket for external module connection
- D - Input/Output (I/O) expansion socket (future development)
- E - External AT disengage
- F - External TO/GA
- G - External Backlight control
- H - Jumpers for firmware upgrade

WARNING! For D, E, F and G auxiliary inputs connection refer to "AUXILIARY INPUTS" section later on this manual. Do not attempt to connect anything different from as described in this section; warranty does not cover damages due to incorrect wiring of any external device.

Only provided stabilized plug-in power supply adapter must be used; do not attempt to plug in a different adapter as you may irreparably damage the MCP. The provided adapter is suitable for 100 to 240 Vac 50/60Hz main supply.

Note: If you do not use MCP for a long time it is preferable disconnect the power supply.

USB DRIVER INSTALLATION

When you connect the MCP for the first time you will ask for the USB driver installation. The drivers are available for download at CPflight website. To install the drivers follows these steps:

- Download the file “usbdriver.zip” at <http://www.cpfight.com/sito/downloads/downloads.asp>
- Files are in a compressed archive .zip; unzip the files in a temporarily folder...
- Connect the USB cable to the MCP737PRO USB connector (Figure 1 “B”) and the other side to a free USB port of your computer...
- Connect the DC power adapter to the MCP737PRO (Figure 1 “A”) and plug the adapter to a main supply socket. The computer has to be switched on when you connect the MCP for the first time...
- The driver installation procedure will start automatically; follows the instruction on the screen (note that the figure of the following example may be different depending by your operating system)...



When you will ask to connect to Menu Update to search for software select “No, not this time” and click next to continue...



Select “Install from a list or specific location” and click next to continue...

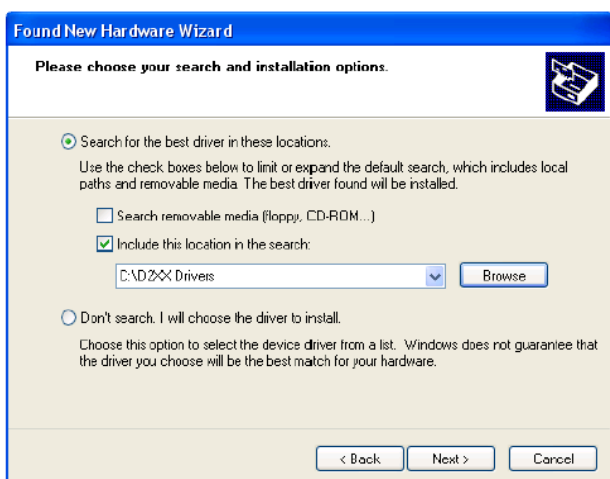

Browse the temporarily folder where you have unzipped the files and click next to continue...



You will be informed that the driver has not been subordinate to Menu Logo testing click “Continue Anyway”...

The drivers will be installed in the system; click “Finish” when prompted.

Important note: Depending by the system you may be required to repeat the driver installation two times.

During the USB drivers installation the system assign a number to the communication port. Check your configuration in the Windows Control panel -> System Property -> Device Manager Tab. On the (COM & LPT) port you will see “CPflight serial adapter (COM n)” where “n” is the assigned communication port number, you will use this number in the First set up (se following).

COMMUNICATION SOFTWARE INSTALLATION

Besides the USB drivers a communication software is needed to use the MCP737PRO with default FS.

Note: the communication software allows to use the MCP737PRO with default FS aircraft. To use the MCP737PRO with Project Magenta it is not necessary to install the communication software as already included in the Project Magenta MCP software.

To install the communication software:

- Download instfs9_xxx.zip (for FS2004) or instfsx_xxx.zip (for FSX) where xxx = revision number at <http://www.cpflight.com/sito/downloads/downloads.asp>
- The file is in a compressed (zip) archive. Extract in a temporary folder and run the exe file to install software (start PC as administrator to install software on Windows 2000/XP/Vista).
- CPflight MCP requires the popular FSUIPC library. If you do not have FSUIPC in your system download it at <http://www.schiratti.com/dowson.html> For FS 2004 download FSUIPC 3.xx, unzip the files into FS9 module folder. For FSX download FSUIPC 4.xx unzip the files in a temporarily folder and double click on "Install FSUIPC4.exe". Note that the CPflight driver doesn't need to register your copy of FSUIPC to use the MCP737 and it's expansions, however we suggest to get the fully registration of your FSUIPC copy to exploit all the auxiliary features allowed by FSUIPC. More information about FSUIPC at <http://www.schiratti.com/dowson.html>

FIRST SET UP AND START-UP

To enable communication with Project Magenta set the communication port number in the Project Magenta "mcp.ini" file. In the Project Magenta MCP folder open "mcp.ini" with a text editor, browse the [Serial Connection] section and set CpflightComm= n in where "n" is the communication port assigned by the system during the USB drivers installation (see the above "Driver Installation" section). Save the "mcp.ini" file. To start-up the MCP737PRO run Project Magenta MCP software.

To start the MCP737PRO with default FS select "Connect" in the FS Add-on menu -> CPflight -> FS-COM. The first time you run FS-COM you will ask to select in the communication port number (Setting COM); set the port number assigned during the USB driver installation (see above).

At the start-up, the MCP737PRO will show on the left "COURSE" and "IAS/MACH" displays the serial number while the right "COURSE" display shows the installed Firmware revision.

The MCP turns off command come from the computer when you close the software. If you shut-down the computer without exit the software or a computer block occur, the MCP may stay on or may fail the subsequent turn on. If you find any problem with the MCP start or turn off, it is advisable to reset the unit. To do this, disconnect the power supply from the MCP, wait few seconds and reconnect power.

Important notes! The MCP can extinguish the displays to simulate a "cold and dark" situation depending by the battery, avionics or other aircraft systems status. Be sure to have the right conditions in the cockpit to have the display turned on.

A/T ARM SWITCH

MCP737PRO comes provided with electromagnetic Autothrottle ARM switch. The switch automatically releases to the "Off" position after the landing touchdown or pressing an external disengage button (see "Expansions" section). The switch release command is sent by the software; the software can switch off the A/T ARM switch also for different reason depending by the status of aircraft systems (fault detected etc.). If the A/T switch does not stay in the "On" position check aircraft conditions. The A/T ARM switch also can be manually disengaged.

ON-FLY DISPLAY BRIGHTNESS AND BACKLIGHT REGULATION

When the MCP is normal running (starts with Project Magenta, PMDG or in test mode using the CPflight test software) you can on-fly set the display and backlight brightness. These functions are not available if the related preferences are settled "On" in the configuration menu (see above "CONFIGURATION MODE" section). To change the display brightness hold pushed the Speed Intervention button and rotates the Right Course knob; to regulate the backlight brightness hold pushed the Speed Intervention button and rotates the Left Course knob. The MCP keep the regulation in its working memory, data are saved in a non-volatile memory when the MCP switch-off (data are not saved if you disconnect the MCP power supply during the normal running).

CONFIGURATION MODE

MCP737PRO firmware provides an internal program mode to configure some preferences in the hardware functionality. With the MCP in stand-by (software not running) push and hold the C/O key for more than 1 second; this start the hardware in configuration mode. This is the only way to access to the configuration mode; no PC software program is required to configure the MCP737PRO hardware. In program mode only some keys are operating; the Left Course, IAS and HDG displays show the program title and option as following:

Left Course display	IAS display	HDG display
Function to be settled	Parameter	Setting

C/O key (push and hold for more than 1 second): enter the program menu.

N1 key: scroll to the next program menu.

SPEED key: toggle the preference setting (ON/OFF).

C/O key: save changes and exit the program menu.

Settings are saved in a non-volatile memory when you exit the configuration menu and the MCP goes in stand-by. Following a description of the menu available in Configuration Mode:

CONFIGURATION MENU	Course display	IAS display	HDG display
<p>BACKLIGHT CONTROL: allow to select how to manage the backlight control. Setting this function to “OFF” (default) the backlight is related to the status of FS NAV lights, so the backlight will light-up when the NAV lights in FS are ON. Setting this function to “ON” the NAV lights status will be ignored and the backlight can be controlled through the related auxiliary input (Figure1 G).</p> <p><i>Note: this setting does not modify the backlight brightness, it select the way to control this variable.</i></p>	EbL	Ctrl	OFF/On
<p>DISPLAY BRIGHTNESS CONTROL (advanced information): allow selecting how to manage the display brightness. Setting this function to “OFF” (default) the display brightness can be regulated during the normal functioning as described above (see “ON-FLY DISPLAY BRIGHTNESS AND BACKLIGHT REGULATION”). Setting this function to “ON” the display brightness can be regulated through a potentiometer connected to the 34 pole connector (future development).</p> <p><i>Note: this setting does not modify the display brightness, it select the way to control this variable.</i></p>	dSP	briG	OFF/On
<p>FAST INCREMENT: this menu allow setting the fast increment functions to the knobs (excluding V/S). Setting this function to “ON” (default) allows the value increase/decrease to be amplified when knobs are rotated fast to rapidly approach the desired value.</p>	FFI	---	OFF/On
<p>SERIAL NUMBER: This menu displays the device serial number. It is a read only location and is not modifiable.</p>	Sn	xxxx	xxx
<p>FIRMWARE RELEASE: This menu displays the installed firmware release. The number is not modifiable in this menu, but it is updated when you load a new firmware in the MCP internal memory (see “FIRMWARE UPDATE” section).</p>	Rel	xxxx	xxx
<p>COUNTER: This menu show the Hours of MCP running. It is a read only location and is not modifiable.</p> <p><i>Note: the “xxxxx” in the above menu act for the total Hours of MCP running from 0 to 99999.</i></p>	Cont	H xx	xxx

EXPANSIONS

MCP737PRO comes provided with wide expansion capability through the DIN 5 pole auxiliary socket (Figure1 “C”). This allows you to connect and interface CPflight plug&play expansion modules (like radio panels and MIP737 expansion board). For further information about modules and expansion boards refer to CPflight website.

AUXILIARY CONNECTIONS

WARNING! The use of auxiliary connector (Figure1 D, E, F, G) is intended for expertise users. To use these auxiliary functions it is necessary to weld wires, to connect external switches/pushbuttons etc. Do not connect anything coming from any external power source or different by the following indications; warranty does not cover damages due to incorrect wiring of any external device.

EXTERNAL A/T DISENGAGE (Figure1 E)

External A/T disengage can accept input from a pushbutton. The pushbutton contact must be open in normal condition and close only when pressed. Releasing the button the contact must return in open condition, do not connect steady position switches (toggles or similar) to this input. When pushing the button the A/T ARM switch disengage independently from any other aircraft system condition.

EXTERNAL TO/GA (Figure1 F)

External TO/GA can accept input from a pushbutton. The pushbutton contact must be open in normal condition and close only when pressed, do not connect steady position switches to this input. The TO/GA function engaging it depends by the aircraft condition and situation (managed by Project Magenta).

EXTERNAL BACKLIGHT CONTROL (Figure1 G)

External backlight control accepts input from steady position switch (ON/OFF) or potentiometer. Connecting a potentiometer you can regulate the backlight brightness directly from this input. Note that the MCP backlight also affects the backlight of the connected modules (if any). The suitable value for the potentiometer is affected by the number of connected expansion modules (EFIS, radios); a 1000 ohm 0,5W potentiometer is suitable for a typical setup. To use the external backlight control set the related preference to “ON” in the preferences setting (see “CONFIGURATION MODE” section).

Important note: when the backlight is controlled through the external control input, it's status it result independent from any other MCP function, so the backlight can be ON also if the MCP lie in stand-by mode.

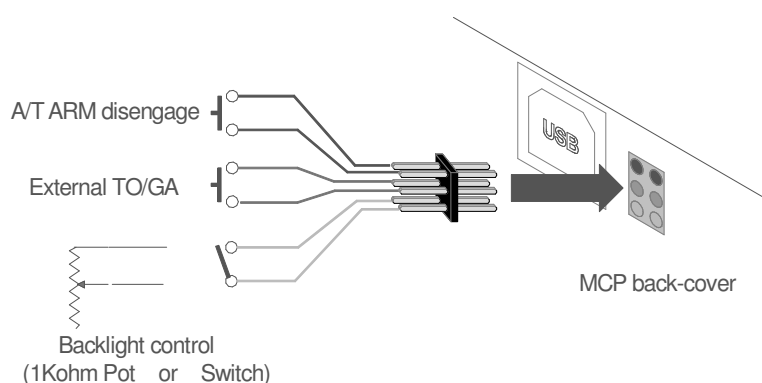

Figure 2: connection diagram for 6 pole auxiliary socket wiring. Note that poles have to be intended as 3 separate 2 pole sockets. From the top to the bottom:

- A/T ARM disengage
- TO/GA
- External back light control

WARNING! To connect wires to the 6 pole socket use the provided 6 pole pin strip; do not weld the wires directly to the MCP connector. Weld wires to the provided pin strip as indicated in the above figure and place thermo-retractile isolation tube on each connection to avoid short-circuit between poles. Do not weld wires to the pin strip when it is inserted in the MCP socket; insert in only after to be finished to weld wires.

34 POLE CONNECTOR (Figure1 D)

The 34 pole connector is provided for future development.

Important note: The 34 pole connector is not compatible with the MCPEX1 expansion board.

FIRMWARE UPDATE

The MCP hardware is based on a microprocessor, on this device run a special program called "firmware". The firmware manages all the hardware functions besides the communication with the computer.

The firmware is stored in a "flash" memory, this allows the program to be updated at any time in case of improvements or functions addition. The firmware is available at CPflight website on download page (except the first released version); the revision number is progressive, so a higher number correspond to a latest version. Before to proceed with the upgrade check the installed firmware revision number. You can see the installed version in configuration mode (see related section) or at the MCP startup.

In some circumstances a firmware upgrade may require an updating of the Project Magenta software too, if you encounter any malfunction after a firmware update, check software version and update the software if required. To update the firmware follows these steps:

- Download the firmware at: <http://www.cpflight.com/sito/downloads/downloads.asp> ; pay attention to the relation between the firmware and the device as on the download page you may find firmware for different devices or MCP version. The firmware for the MCP737PRO is named "mcpprofxxx.zip" (where xxx act for the revision number)...
- Files are in a compressed archive .zip; unzip the files in a temporarily folder...
- Disconnect supply from the MCP; disconnect external modules and expansion board if any...
- Insert the two jumpers (provided) on the pins located on the back of the MCP as indicated in the below figure...

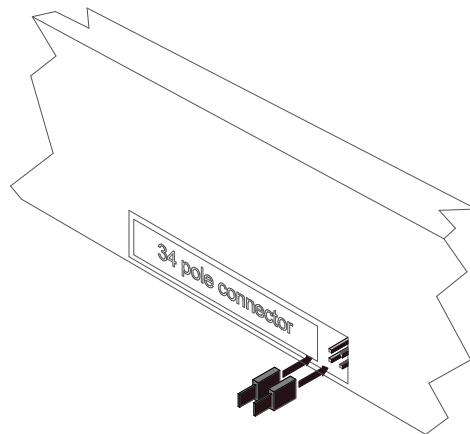

- Connect power supply to the MCP, a small flash on the backlight indicate that the MCP has started in firmware program mode...
- Close any application on the computer, browse the temporary folder that contain the downloaded firmware and run UPGRADE.EXE program. The following dialog will prompt...

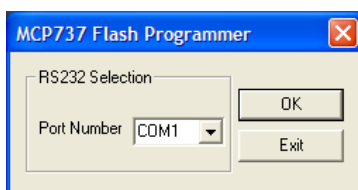

Select the port number assigned during the driver installation (see "driver installation" section) and click on OK...

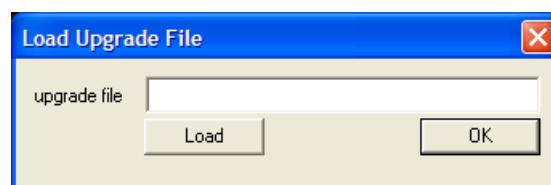

...click on "Load" button and browse the MCP737PROxxx.mot file (where xxx represent the release number) in the folder where you have extracted the firmware files; select it and proceed...

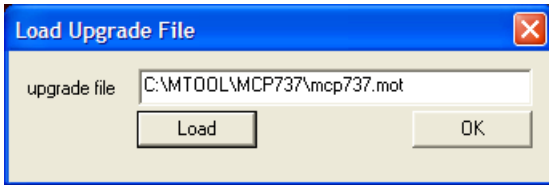

...the file name will be shown into "upgrade file" field click OK to proceed...

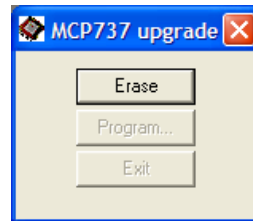

...click on the Erase button to clear the memory for programming...

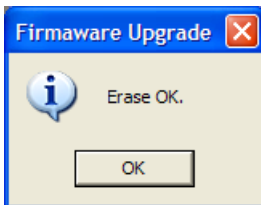

...at the end of erase phase the above dialog will prompt; click OK to proceed...

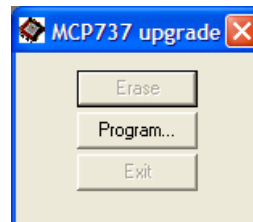

...now click on Program... button...

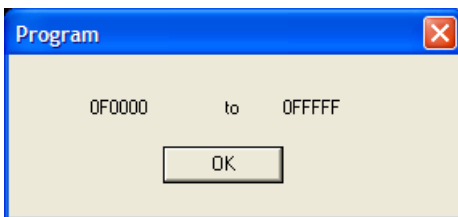

...the program show the info about the memory area to be programmed, click OK...

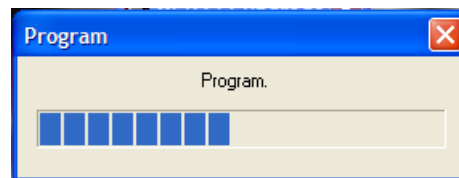

...the memory programming will take some time, during the programming the MCP backlight will flash...

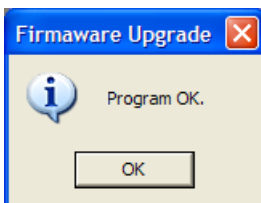

...at the end of program procedure the above dialog will prompt, click OK to continue...

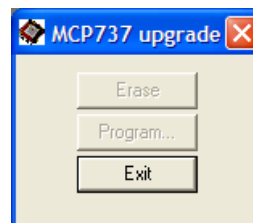

...now click to Exit button and wait until the dialog will close before proceed...

- Firmware has upgraded; disconnect supply from the MCP...
- Remove the two jumpers from the pin...
- Reconnect external modules and expansion board if any...
- Reconnect power supply to the MCP, the displays will show the new installed Firmware revision.

MAIN CHARACTERISTICS

- Engravity high resolution backlighting frontplate.
- Backlight color: Warm White
- Engravity back lighted pushbuttons.
- Pushbuttons legend backlight color: Green
- Displays: Altitude, Vertical Speed, Heading, Speed, Left Course and Right Course.
- Display characteristics: LED 7 segments. Digit height: 0,3" (7,6mm)
- Display color: white
- Digital long life (min 500.000 cycle) encoders to set: Altitude, Heading, Speed, Left and Right Course
- Horizontal digital encoder to set Vertical Speed (15 increment for turn).
- V/S encoder characteristics: 15 increment for rotation (with detent).
- Knobs: aluminum dust-coated (with symbols on course knobs)
- Dual concentric HDG-SEL knobs with 5 positions BANK ANGLE limit selector (10°, 15°, 20°, 25°, 30°)
- Electromagnetic disengage Auto Throttle ARM switch with Green LED indication.
- Toggle switches for Left and Right Flight Director with "MA" Amber LED indication.
- Disengage bar.
- C/O, Speed and Alt Intervention round buttons.
- External or internal display brightness regulation.
- External or internal backlight brightness regulation.
- 16 bit Flash microcontroller.
- DIN 5 pole socket for plug&play CPflight modules interface.
- USB Interface (USB cable provided).
- Supply: 6Vdc 1A (supply adapter provided).

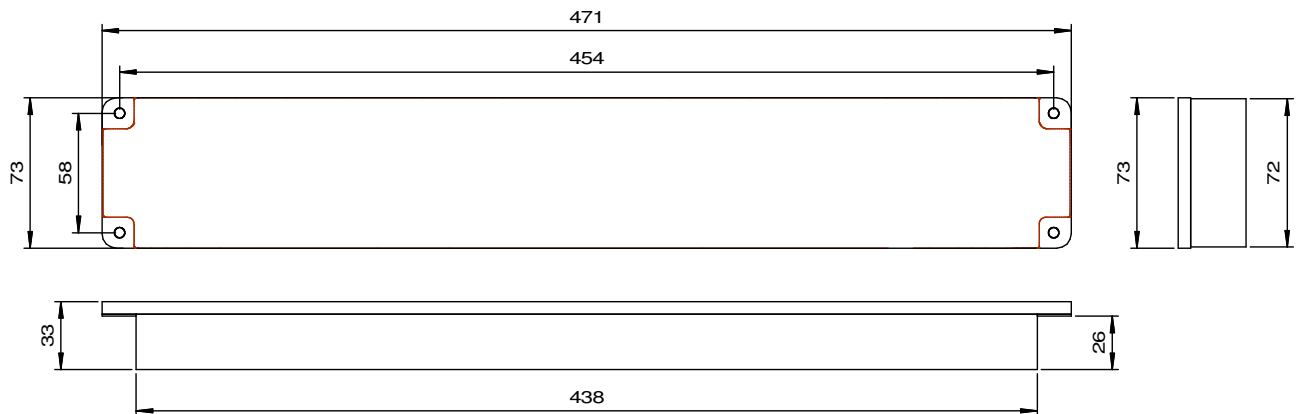

Figure 3: Mechanical Dimensions (mm)

LINKS

Web site: <http://www.cpflight.com>
 Support: <http://www.cpflight.com/sito/help/mainsupport.asp>
 Email: info@cpflight.com

APPENDIX:

PANEL CUT-OUT

Dimensions are in millimeters. In the panel fixing cut-out consider the front-plate overhang.

